







**IN8188**

**Bulkhead - VG323S / VG323P**

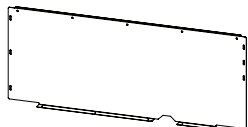
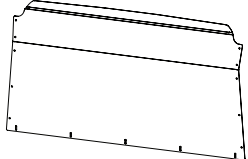
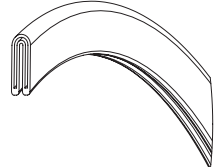
<p><b>AS3301 X1</b> (RIGHT)</p> 	<p><b>AS3302 X1</b> (LEFT)</p> 	<p><b>AS3300 X1</b> (BOTTOM)</p> 	<p>VG323S = <b>ME0969 X1</b> VG323P = <b>ME0970 X1</b> (TOP)</p> 	<p><b>MA6030 X1</b> (RUBBER EDGING 1640MM)</p> 	<p><b>FX4010 X21</b> (M6)</p> 	<p><b>FX4012 X21</b> (M6X16)</p> 
		<p><b>FX4017 X21</b> (M6)</p> 	<p><b>FX4090 X16</b> (No8 x 1/2")</p> 			

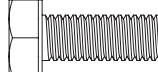
**CAUTION - IMPORTANT NOTES**

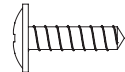
1. You should note that it is the responsibility of the installer/s to ensure that when drilling holes in to your vehicle to take fixings, care must be taken to ensure that the fuel line, tyres, fuel tank, wiring loom, exhaust, bodywork and brake lines etc. are not damaged. Whilst every effort has been made to ensure our products can be safely fitted, changes to vehicles sometimes occur so it's always necessary to check before drilling.

**If in doubt refer to the vehicle manufacturer's dealership.**

- 2. When drilling, use as short a drill bit as possible to prevent damage to the vehicle. Use corrosion protection when drilling the vehicle.
- 3. Wear the appropriate protective equipment (safety glasses & gloves) while fitting this product.
- 4. Regularly inspect all fixings and parts. Any damaged or worn parts should be immediately removed the vehicle and replaced.
- 5. Retain instructions for future use. It is important that the end user receives this document.

**TOOLS REQUIRED**

SPANNER (10MM) X1



PH SCREW DRIVER X1



DRILL (Ø3.2MM) X1

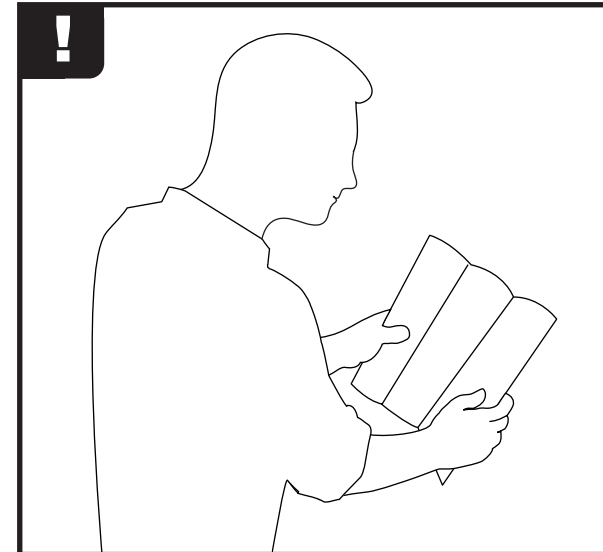
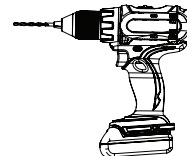

This FITTING INSTRUCTION is the property of VAN GUARD ACCESSORIES LTD. and must not be used for manufacturing purposes, copied nor communicated in any way to third parties without written permission from VAN GUARD ACCESSORIES LTD.

IN8188\_B

Van Guard Accessories Ltd  
Fair Oak Close, Exeter Airport Business Park,  
Exeter, Devon, EX5 2UL  
www.van-guard.co.uk

**1** Fit the rubber edging (MA6030) to the top edge of the top bulkhead.

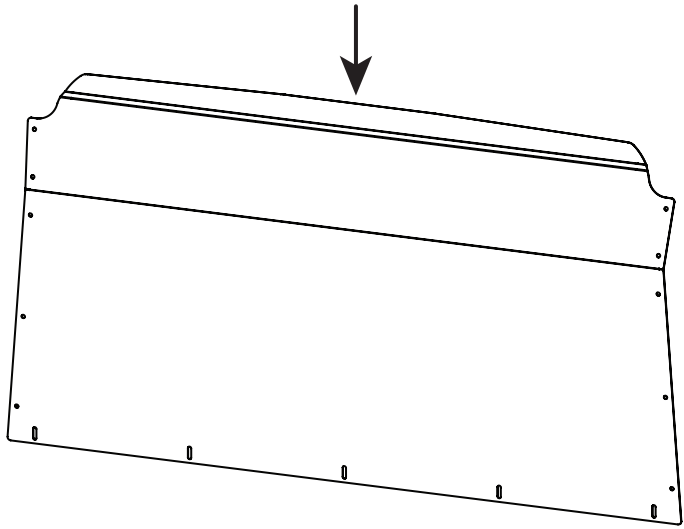

**2** Lift the bottom bulkhead into the vehicle with the bottom return facing into the load area. Place into position with the bulkhead against the passenger's seat.



**3** Lift the top bulkhead into the vehicle and **loosely** secure to the bottom bulkhead in 5 positions using M6x16 hex bolts (FX4012), M6 shakeproof washers (FX4010) and M6 washers (FX4017).

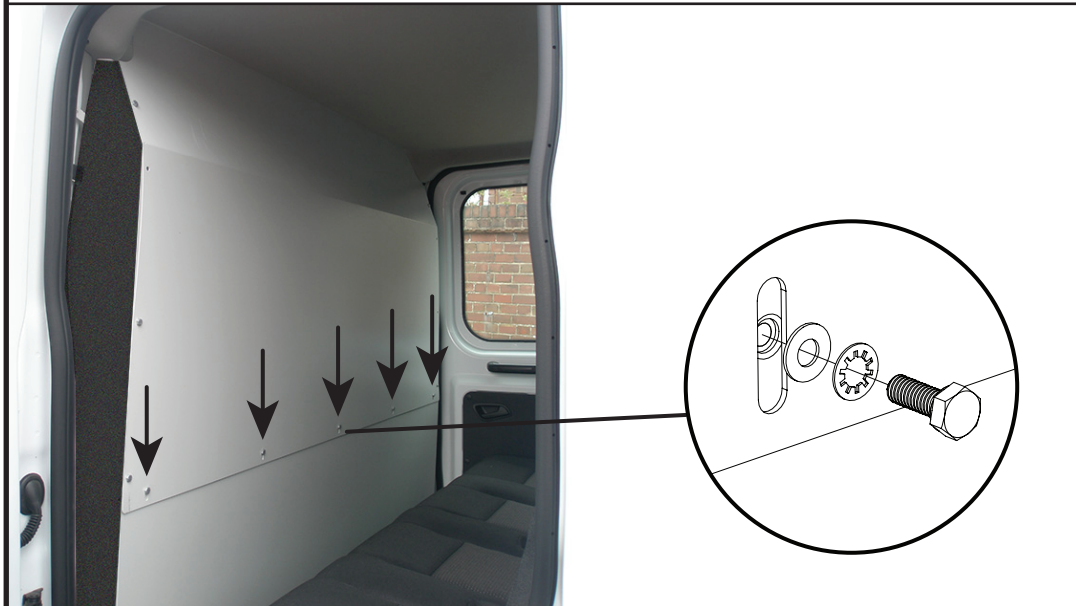

**4** Secure the sides to the bulkhead using M6x16 hex bolts (FX4012), M6 shakeproof washers (FX4010) and M6 washers (FX4017) (8 position each side). Once the sides are in position lift the top bulkhead upwards to the top of the roof and tighten all fixings.

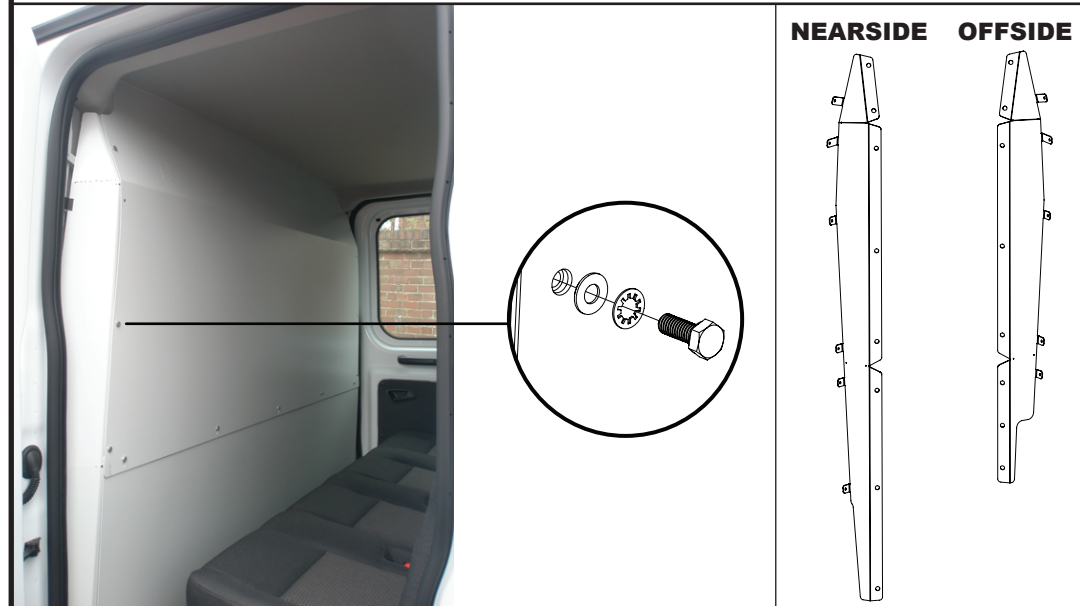

**5** Once happy with the position of the bulkhead carefully drill 3.2mm through the fixing tabs and into the vehicles 'B' pillar. Secure to the pillar using No8x1/2" self-tap screws (FX4090) (11 positions).

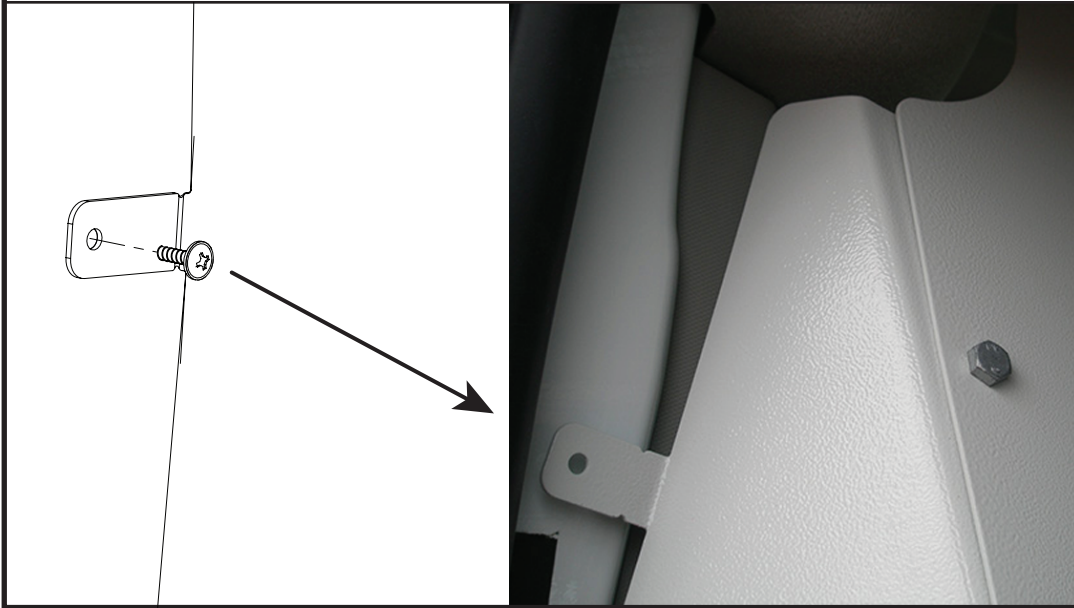

**6** Carefully drill 3.2mm through the 5 positions along the bottom flange of the bottom bulkhead and secure to the vehicle using No8x1/2" self tap screws (FX4090).

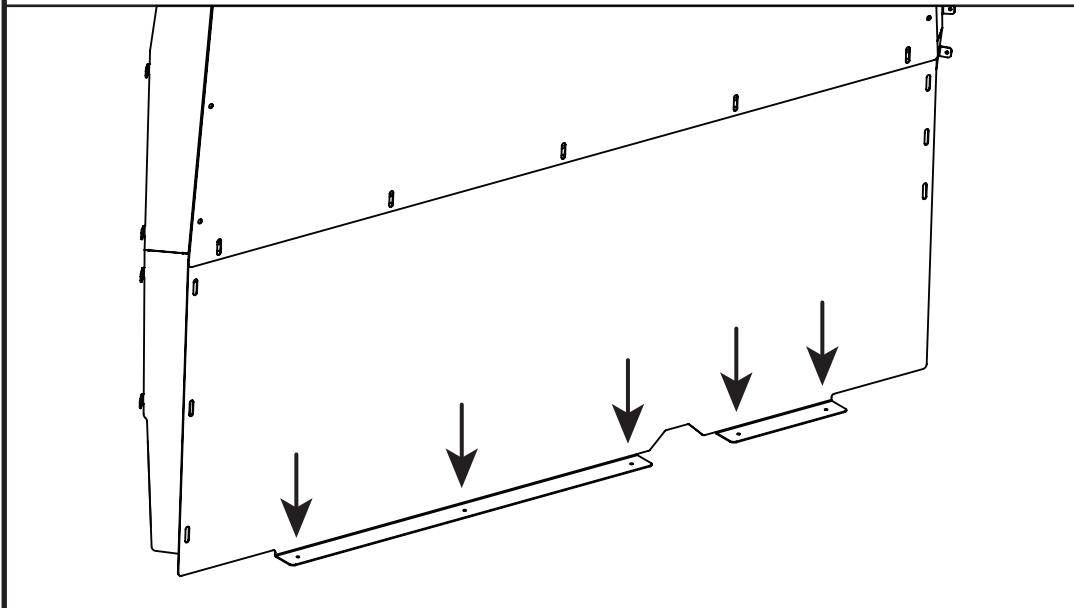

**EXAMPLE IMAGE**

